

Steam/Water/Gas Orifice Flow Meter	
Industrial/ Marine Application	Model : LKS-SFDIS

Functions & Features

LKS Steam flow monitoring is design to detect/ measure steam flow on piping. The pressure transmitter brings true precision to measurement of flow, level, gage and absolute pressure, vacuum, and specific gravity.

Complete set



Operation

During operation, the isolating diaphragms and fill fluid on the high and low sides transmit the process pressure to the oil fill fluid. The fluid in turn transmits the process pressure to a sensing diaphragm in the center of δ -cell sensor. The sensing diaphragm functions as a stretched spring element that deflects in response to differential pressure across it (in GP transmitters, atmospheric pressure is transmitted in a like manner to the low side of the sensing diaphragm). In AP Transmitters, a reference pressure is maintained on the low side. The displacement of the sensing diaphragm, a maximum movement of 0.004 in.(0.10mm), is proportional to the pressure. Capacitor plates on both sides detect the position of sensing diaphragm. The differential capacitance between the sensing diaphragm and the capacitor plates is converted electronically to an appropriate current, voltage, or digital HART[®] (Highway Addressable Remote Transducer) output signal.

Function and Specification:

Service	Steam (vapor application), Liquid and gas.
Ranges	30 inH ₂ O, 100 inH ₂ O, 150 inH ₂ O, 750 inH ₂ O, 100 psi, 300 psi, 1000 psi, 3000 psi & 6000 psi
Output Signal	Code S, Smart: 4-20mA dc, user selectable for linear or square root output. Code E, Analog: 4-20mA dc, linear with process pressure. Code G, Analog: 10-50mA dc, Linear with process pressure Code J, Analog: 4-20mA dc, square root of differential input pressure between 4 and 100% of input. Linear with differential input pressure between 0 and 4% of input. Code L, Low power: 0.8 to 3.2 VDC, linear with process pressure. Code V, Low power: 1 to 5V dc, linear with process pressure.
Power Supply	External power supply required. Transmitter operates according to the following requirements: Output code S, E, J 12 to 45 VDC with no load. Output code G 30 to 85 VDC with no load. Output code L 5 to 12 VDC. Output code M 8 to 14 VDC

Code	V _{min}	V _{max}	R _{min}	R _{max}	RL at Supply Voltage (V _S)
S ⁽¹⁾	12	45	0	1650	RL=43.5 (V _S -12)
E,J	12	45	0	1650	RL=50(V _S -12)
G	30	85	0	1100	RL=20(V _S -30)
L	5	12	Low power minimum load impedance: 100K Ω		
M	8	14			

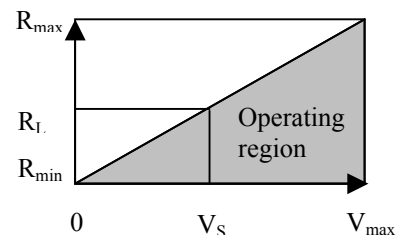

Our policy is one continuous improvement, therefore the information contained in this catalog may be subject to change without prior notice and does not form any part of contract between LKS (M) SDN. BHD. and customer.

Assemble: LKS (M) SDN BHD Tel:603-51240822, Fax:603-51240222, E-mail: info@lkssb.com.my www.lkssb.com.my

Current Consumption	Output code L: 1.5mA, code M: 2.0mA
Output codes E,G,J,L & M	span and zero ares continuously adjustable.
Temperature limit	
	Code S -40 to 85°C
	Code E -40 to 93 °C
	Code G,L,M -20 to 200 °C
	Code J -20 to 150 °C
Sensing element operating	
	Silicone fill -40 to 104 °C
	Inert fill -18 to 71 °C
Storage	
	Code S -51 to 85 °C
	Codes E,G,L,M -51 to 121 °C
	Code J -51 °C to 82 °C
Static pressure limits	Transmitter operate within specifications between the following limits:
Model 1151DP	0.5 PSI (3.45 kPa) to 2,000 PSI (13,790kPa)
Model 1151HP	0.5 PSI (3.45 kPa) to 4,500 PSI (31,027kPa)
Model 1151AP	0 PSI to the URL
Model 1151GP	0.5PSI to (3.45 kPa) to the URL

ORDERING INFORMATION

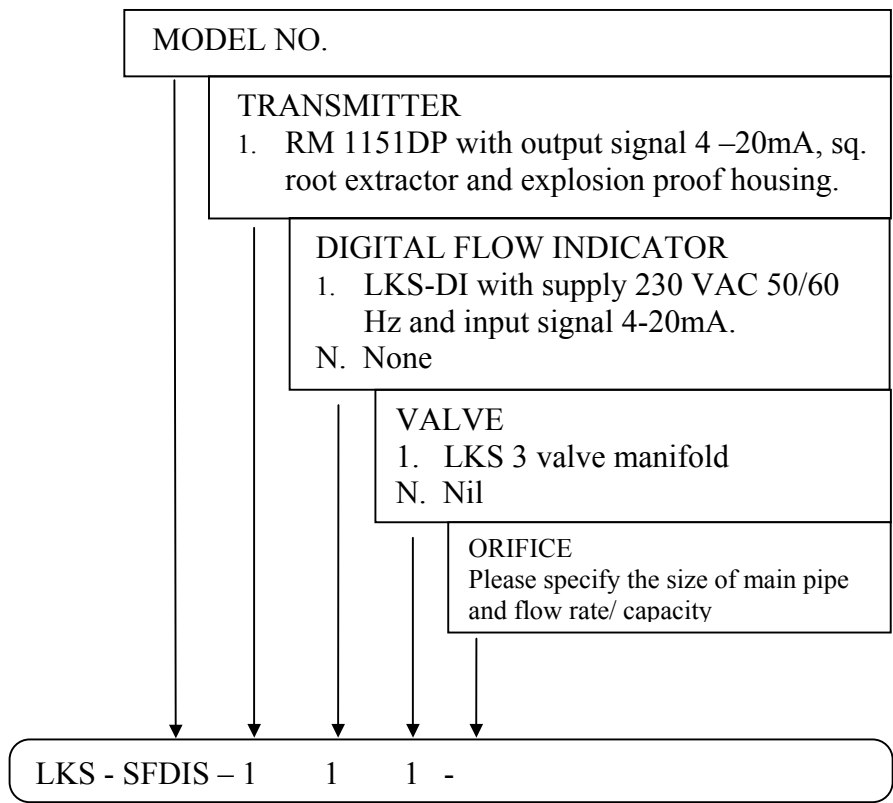

Distributor:

Typical installation with wiring diagram

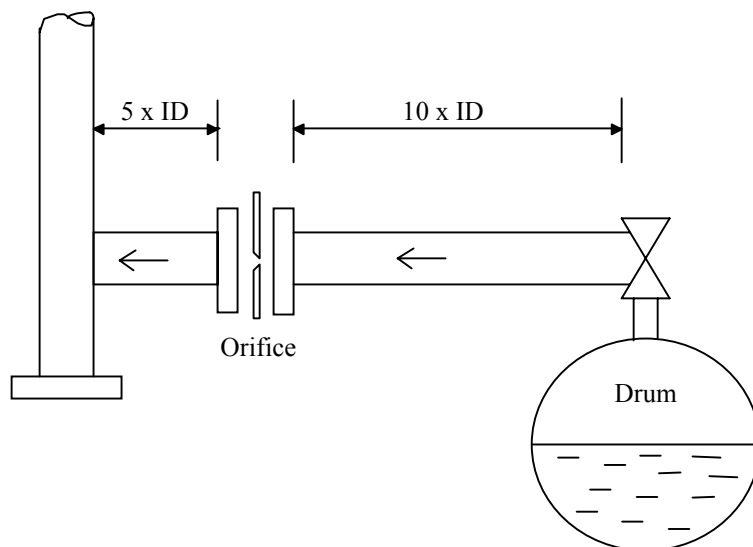
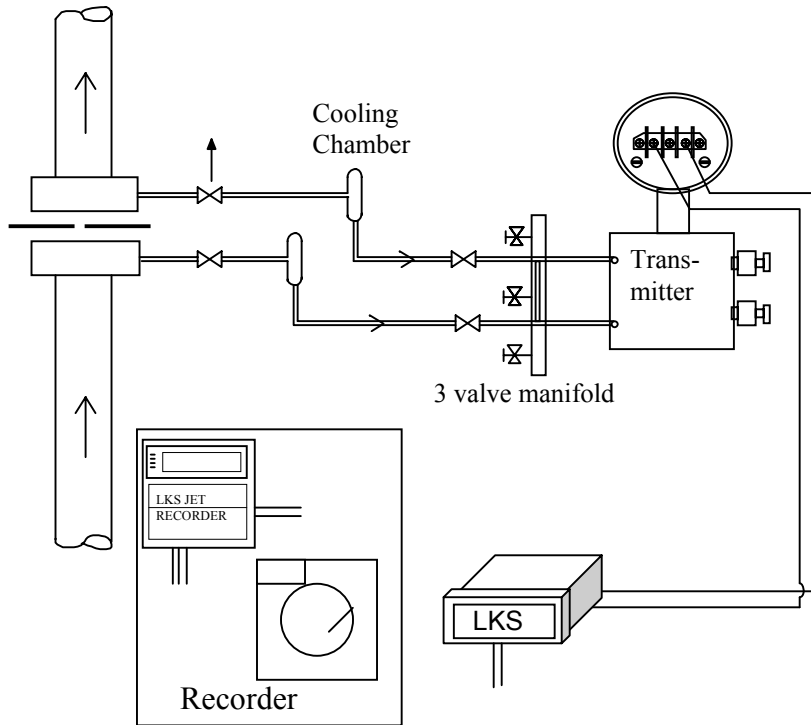

REFERENCE

The OEM or Boilermaker, which used our complete boiler, controls system with out fabrication motor panel.